

(RMO4A-2)

An Energy Efficient OOK Transceiver for Wireless Sensor Networks

Denis C. Daly and Anantha P. Chandrakasan

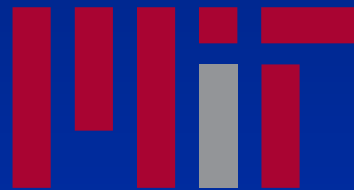

Massachusetts Institute of Technology
50 Vassar St. Room 38-107
Cambridge, MA, USA 02139



Outline

- System overview
- Receiver front end optimization
- Circuit implementation
- Measurement results



Transceivers for Sensor Networks

- Sensor network specifications:
 - Closely spaced nodes: ~10 meters apart
 - Average power: 10 μ W to a few mW
 - Data rate: <10 kbps
- Both power *and* energy efficiency critical
- Transceiver must be duty cycled



Goal: *To design a custom, energy-efficient wireless transceiver for wireless sensor networks*



Architecture

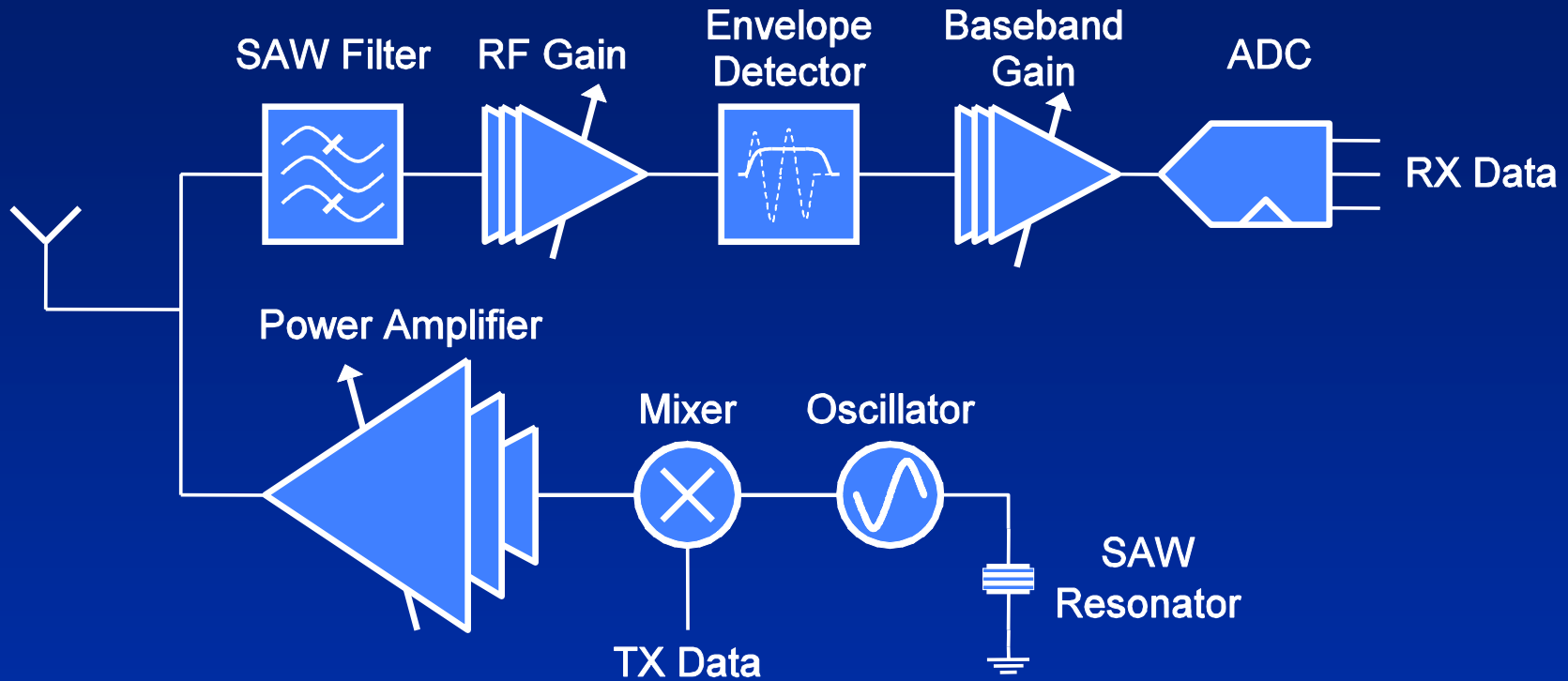

- On-off keying (OOK) modulation
- 1 Mbps at 916.5 MHz carrier



Architecture

Advantages

- Fast RX startup time
- No oscillator required for receiver
- Receiver circuit power scales with gain
- No PLL required for transmitter

Disadvantages

- Higher SNR required
- Single channel is susceptible to interferers
- Requires offchip SAW components
- Significant RF gain is required in receiver



Scalable Receiver

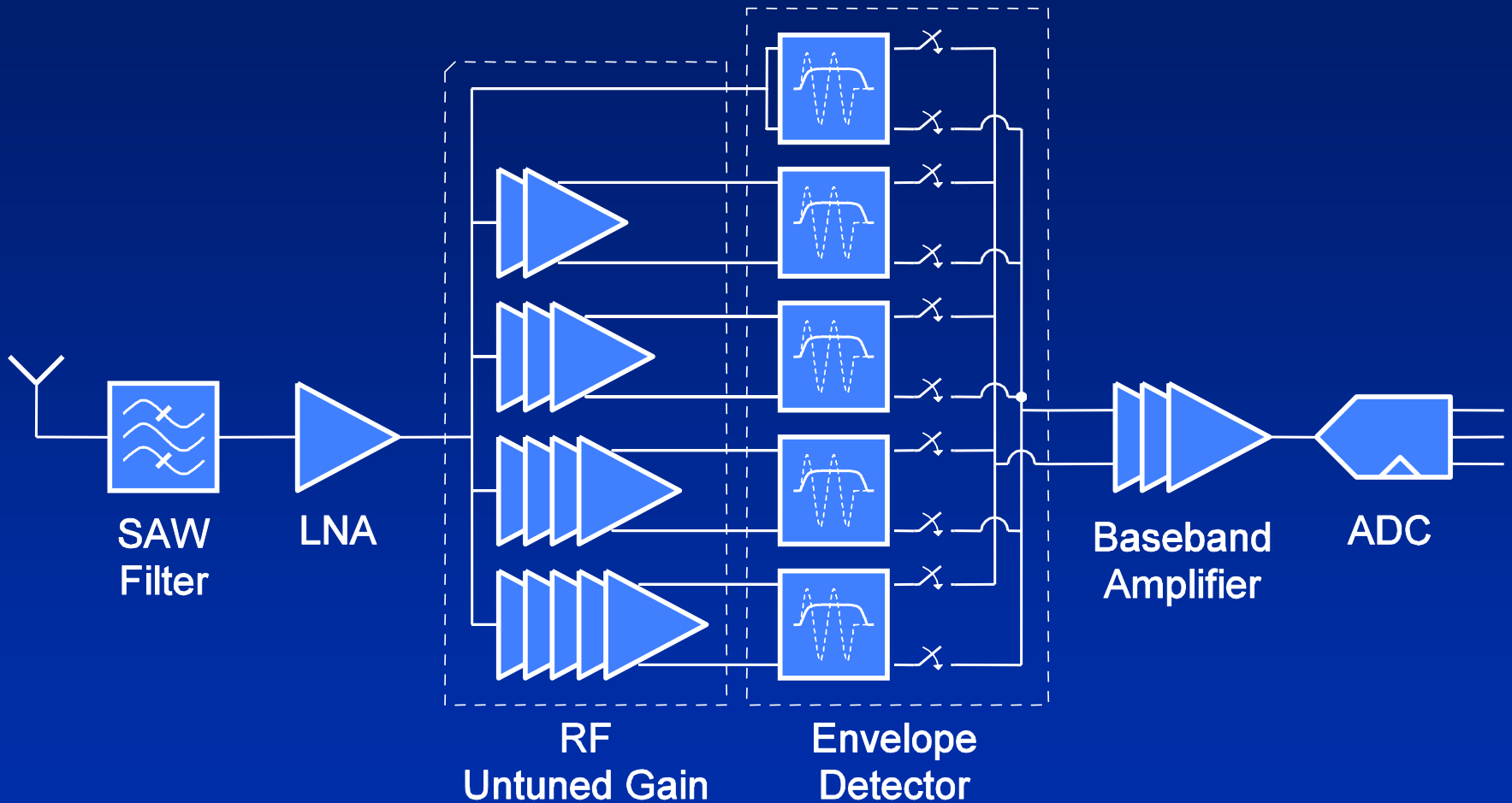

RF and baseband gain scalable to achieve optimum energy efficiency



RF Gain – Untuned vs. Tuned

- What is the most energy efficient way to generate 45dB of RF gain?

Untuned RF gain

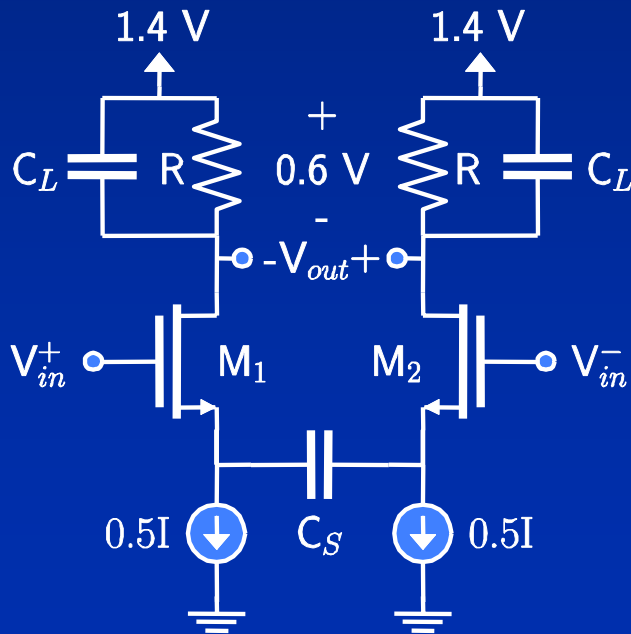

Tuned RF gain

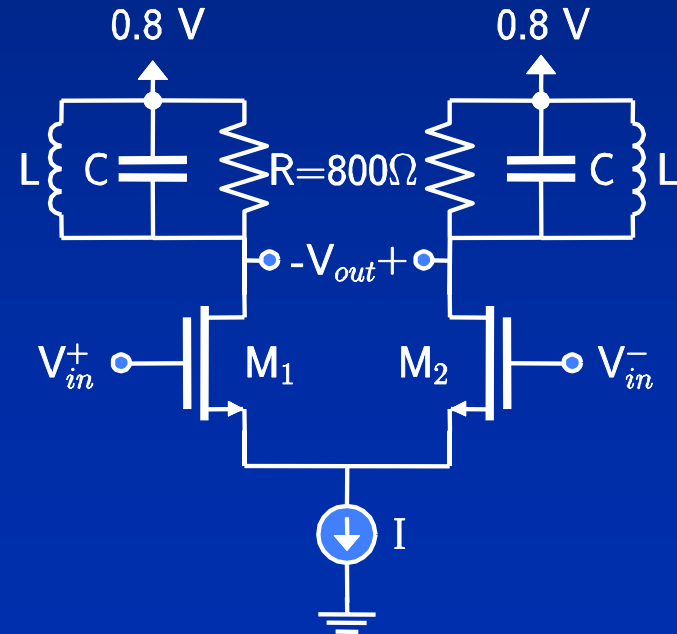

Untuned RF Amplifier

Resistors sized for noise constraints

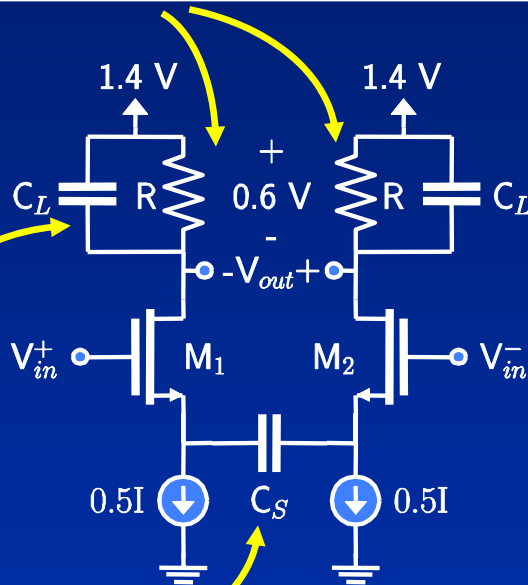

No significant load inductors or capacitors

Input ac coupling capacitor at source allows for minimal gain reduction due to parasitics

Input low frequency noise filtered

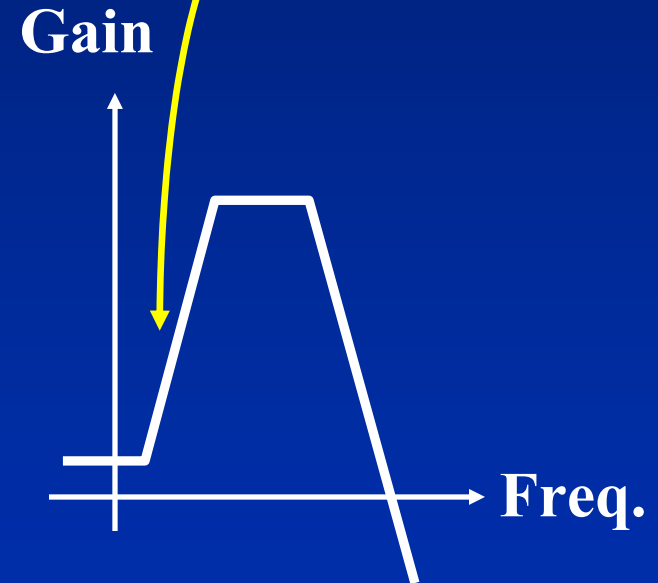

RF Gain - Optimization

Efficiency Metric:

$$\frac{\log(\text{Gain})}{\text{Power}}$$

Efficiency of untuned gain

Efficiency of tuned gain

Comparable efficiency to tuned gain

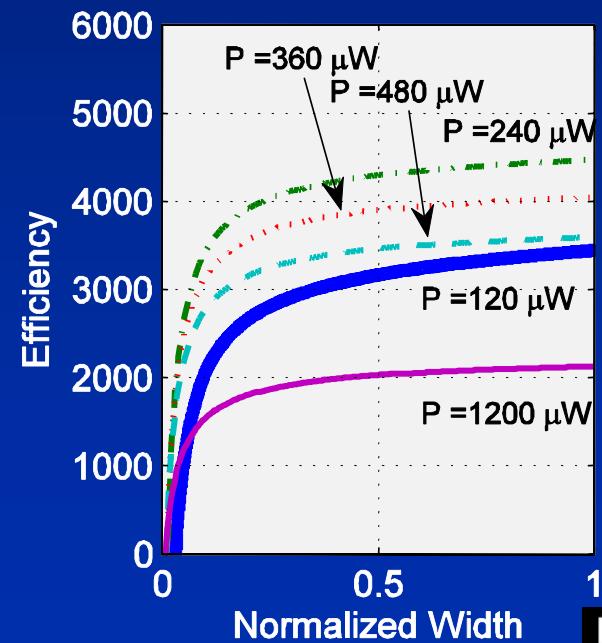
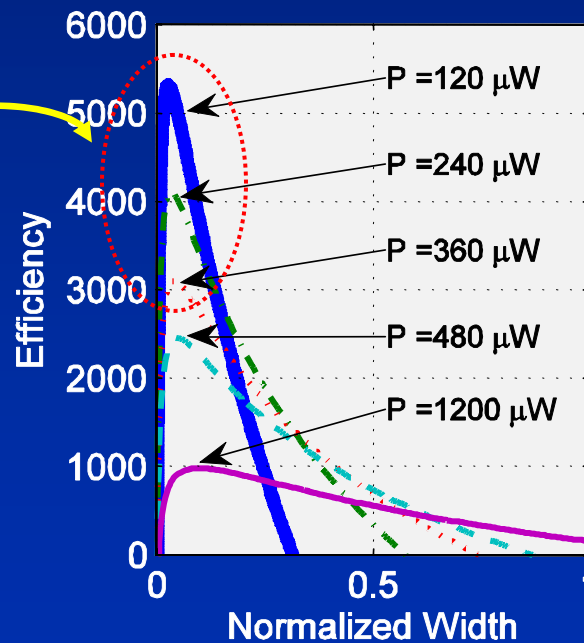

RF Front End Architecture

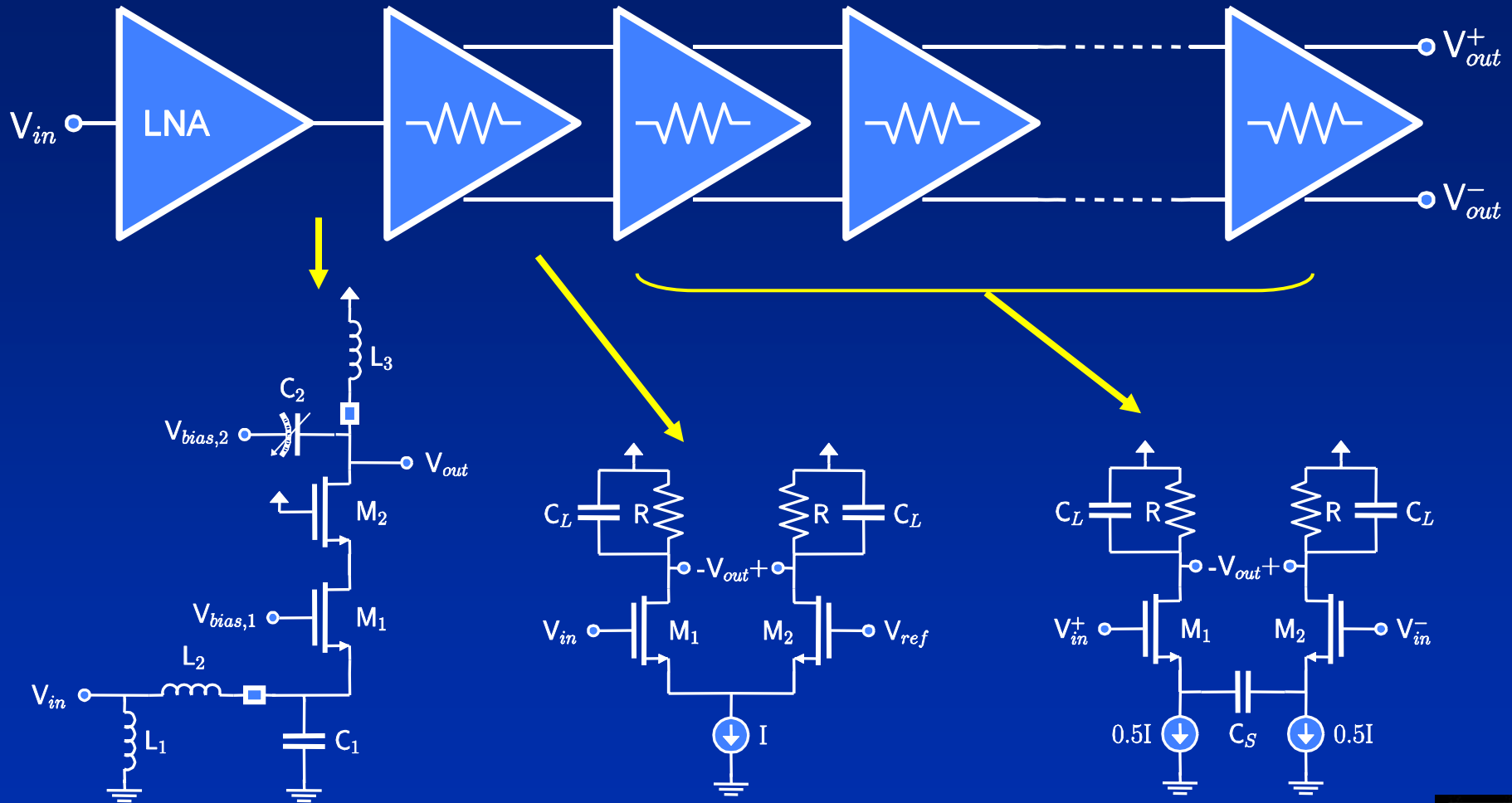

Early stages supplied additional current to meet noise constraints



Envelope Detector

- Envelope detector is a differential pair, with the output at the source terminal
- There are multiple inputs, each corresponding to a different RF gain setting

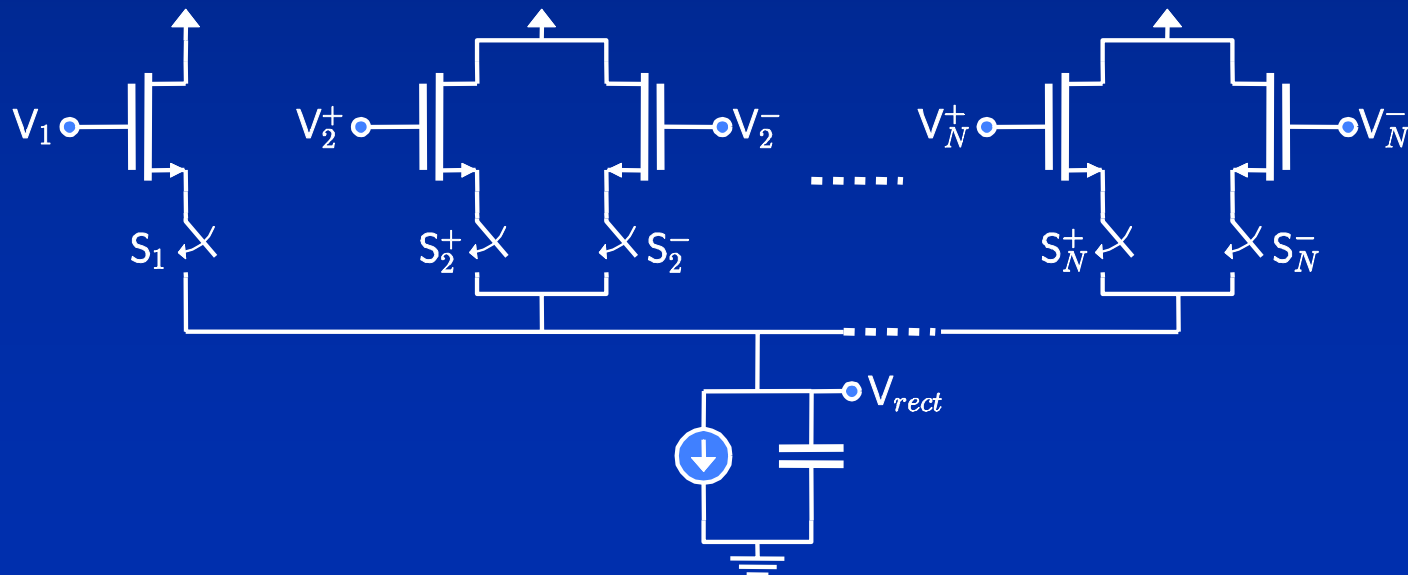

Baseband Amplifier and ADC

- 3-stage baseband amplifier
- ADC is 8 MSPS, 3-bit flash converter

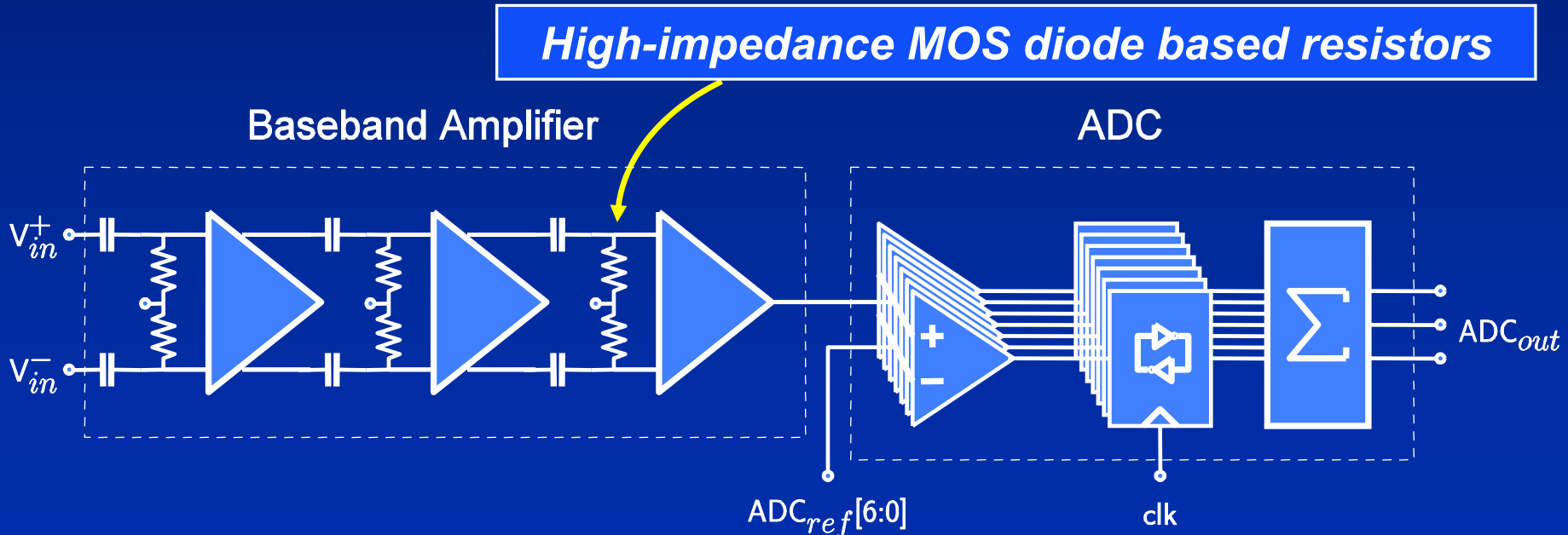

Open-loop amplifiers with passive offset compensation for low power operation



Transmitter

- Mixer integrated with power amplifier
- Scalable P_{out} from -11.4 dBm to -2.2 dBm
- Maximum power efficiency of 6.9%

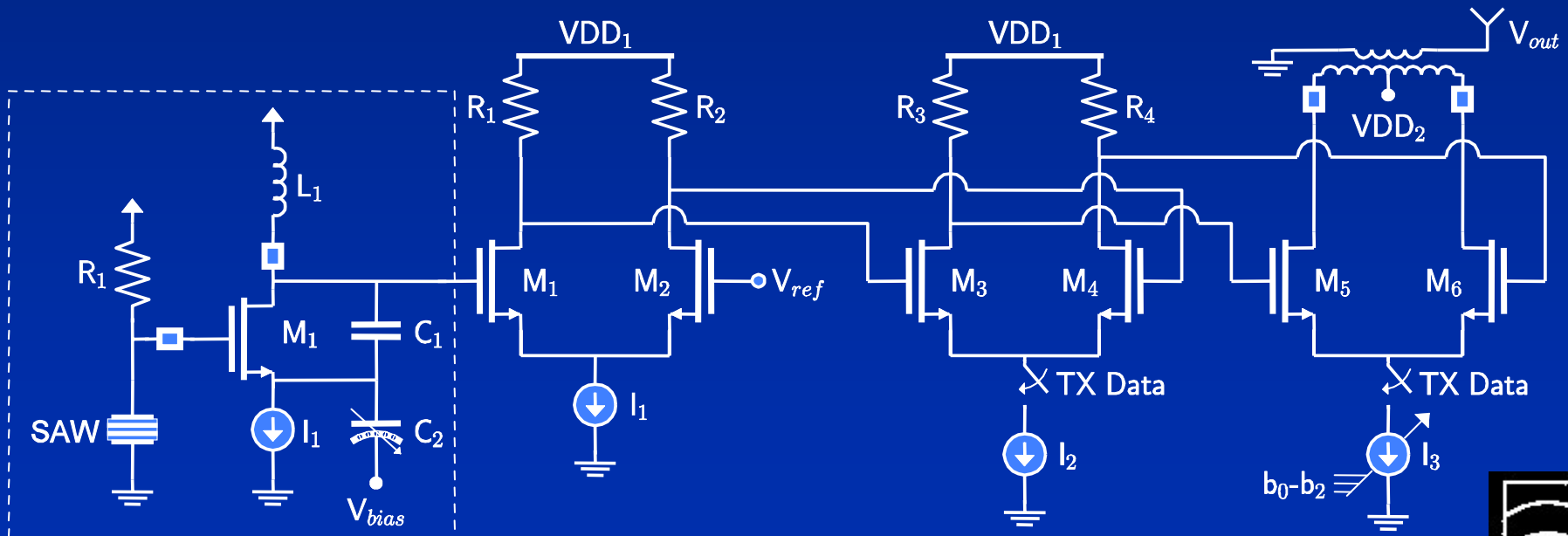

SAW Stabilized Oscillator



Die Photo

1.3mm by 1.4mm
Active Area: 0.27mm²

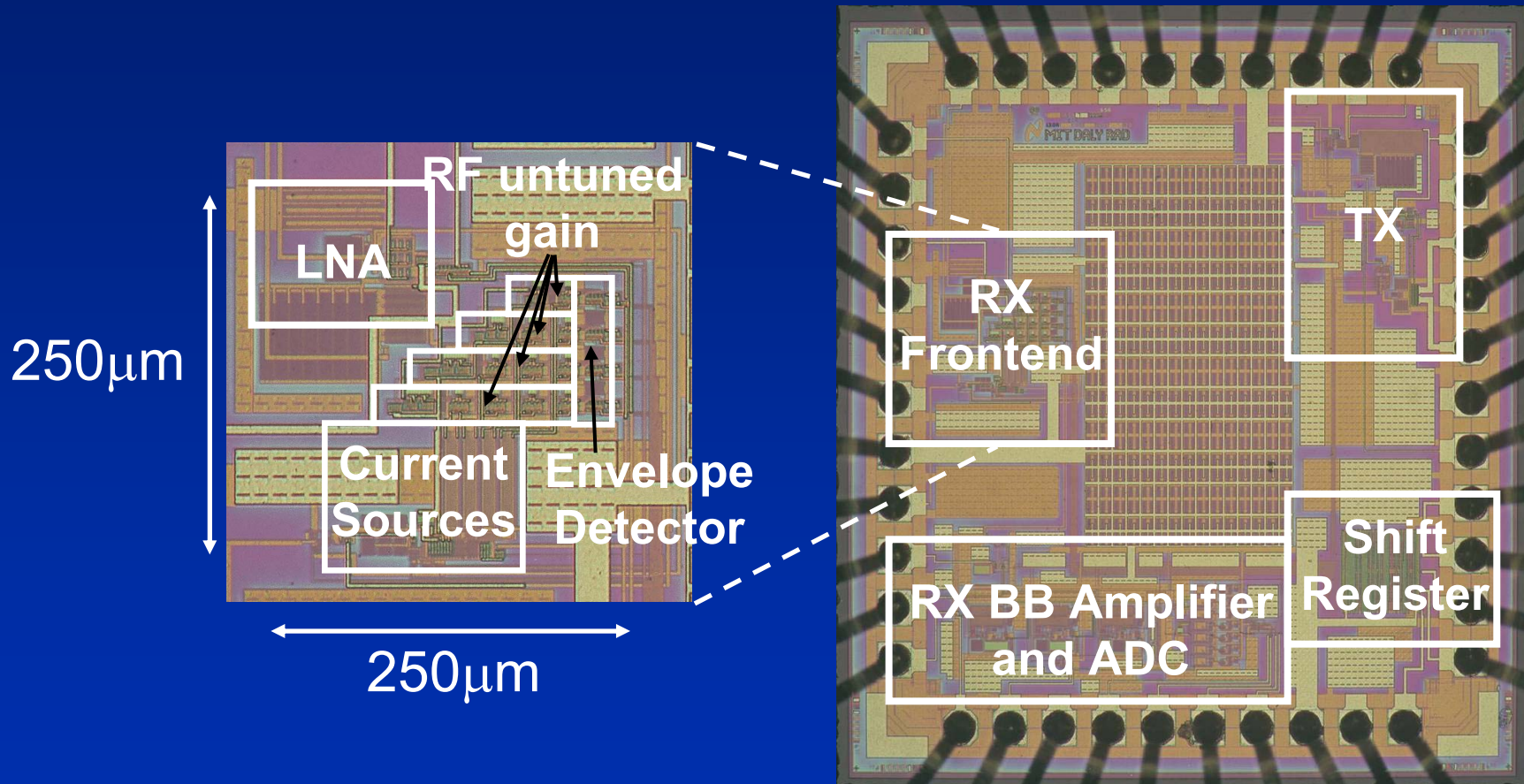

Measured Results

Specifications							
Data Rate	1 Mbps						
Center Frequency	916.5 MHz						
Technology	0.18 μ m CMOS						
Die Area	1.3mm by 1.4mm						
Receiver (5 gain settings)							
Power consumption (mW)	2.6	2.4	1.7	1.2	0.5		
Sensitivity at 10 ⁻³ BER (dBm)	-65	-62	-58	-49	-37		
Startup time	2.5 μ s						
Transmitter (7 power settings)							
Power consumption (mW)	3.8	4.8	5.8	6.7	7.6	8.3	9.1
Output Power (dBm)	-11.4	-7.2	-4.9	-3.6	-2.9	-2.4	-2.2
Startup time	<60 μ s						



Receiver Results

Rectifier output versus RF input power

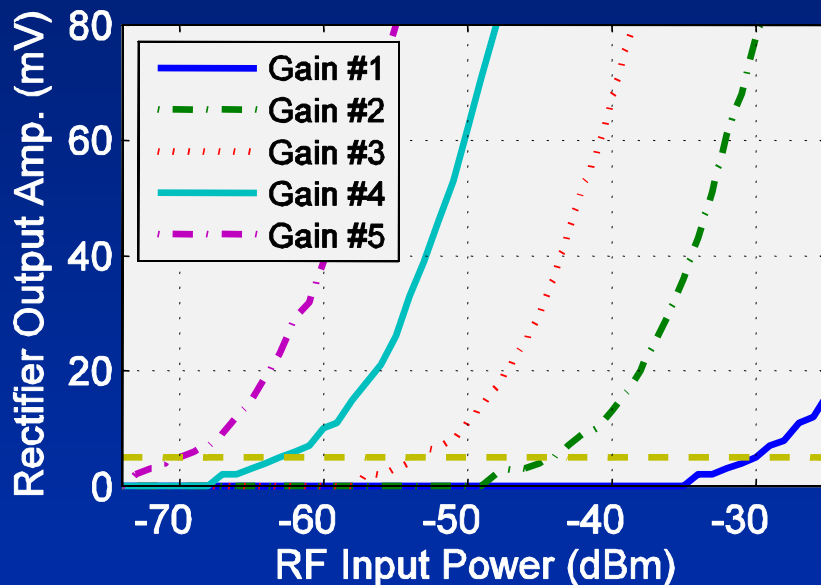

BER versus RF input power

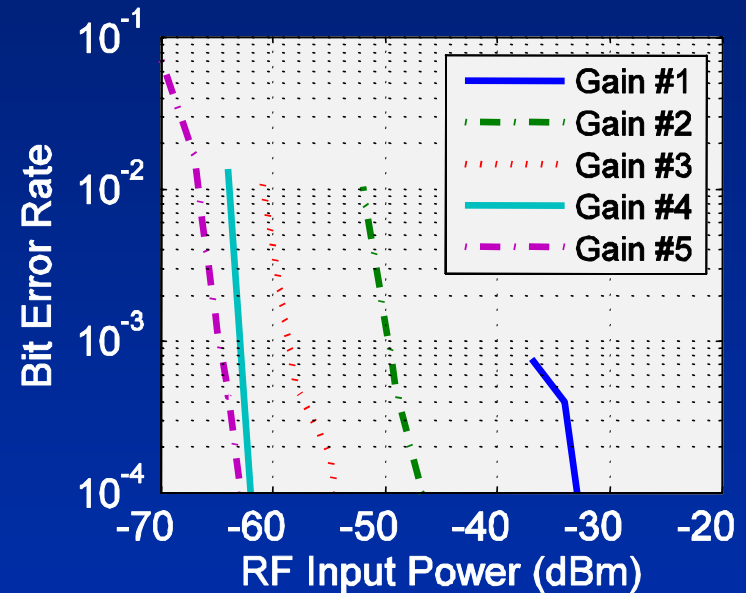

- BER limited by RF noise, not gain at small input power levels



Transmitter Results

Transient Response

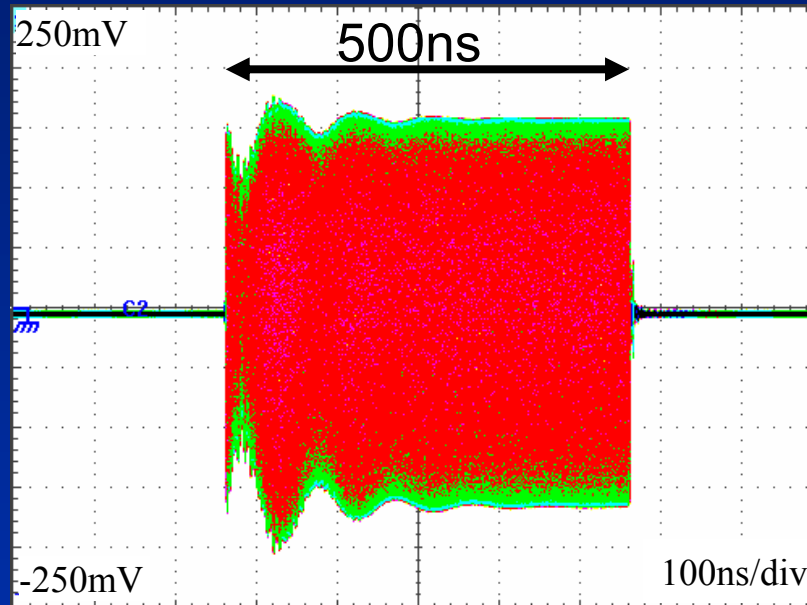

- Data is Manchester encoded to remove dc content



Energy Per Bit Ratio

- For 50 bit packet, startup energy overhead:
 - RX overhead of 5%, TX overhead of 25%

Receiver

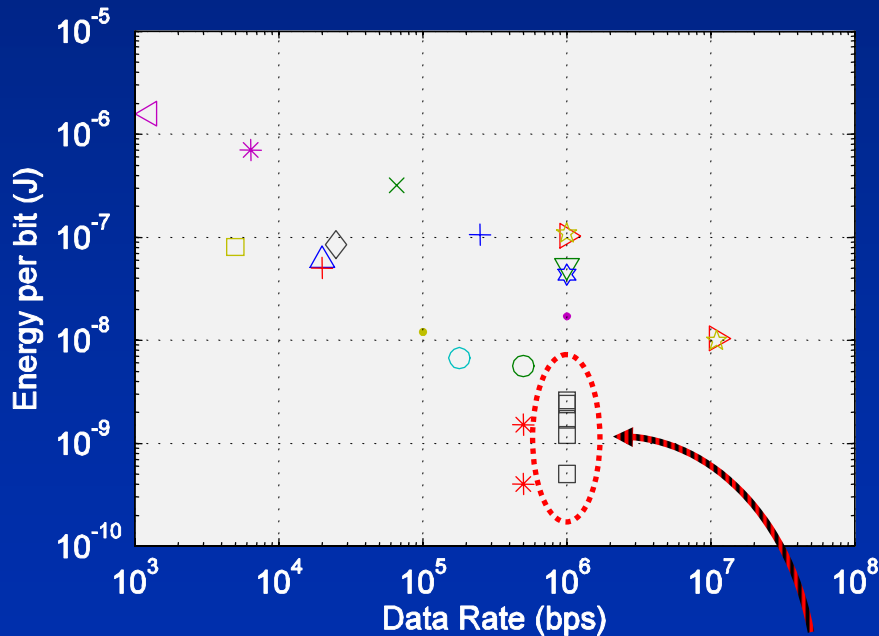

Transmitter

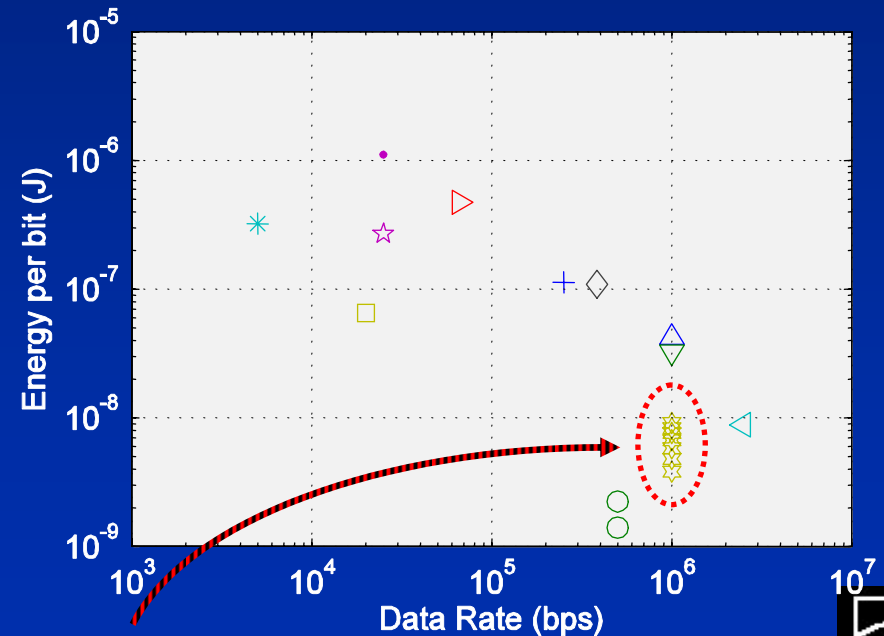

This work

RFIC - San Francisco June 11-13, 2006



Summary

- An energy-efficient, highly scalable transceiver has been designed for sensor networks
- It achieves a minimum energy per bit ratio of:
0.5 nJ/bit for the RX and 3.8 nJ/bit for the TX
- The architecture lends itself well to process scaling



Acknowledgements

- DARPA PAC/C
- National Semiconductor for chip fabrication
- NSERC Postgraduate Scholarship

