

Development of Specialized Basis Functions and Efficient Substrate Integration Techniques for Electromagnetic Analysis of Interconnect and RF Inductors

X. Hu, T.A.E. Moselhy, J. White, L. Daniel
Sponsorship: SRC/FCRP GSRC, NSF

The performance of several mixed-signal and RF-analog platforms depends on substrate effects that need to be represented in the library model with critical field solver accuracy. For instance, substrate-induced currents in RF inductors can severely affect quality and hence RF filter selectivity. We have developed an efficient approach to full-wave impedance extraction that accounts for substrate effects through the use of two-layer media Green's functions in a mixed-potential-integral-equation (MPIE) solver. In particular, we have developed accelerated techniques for both volume and surface integrations in the solver.

In this work, we have also introduced a technique for the numerical generation of high-order basis functions that can parameterize the frequency-variant nature of cross-sectional conductor current distributions. Hence skin and proximity effects can be captured

utilizing fewer high-order basis functions in comparison to the prevalently used piecewise-constant basis functions. One important characteristic of these basis functions is that they need to be pre-computed only once per unique conductor cross-sectional geometry, and then stored off-line with a minimal associated cost. In addition, the robustness of these frequency-independent basis functions is enforced using an optimization routine.

We have shown in [2] that the cost of solving a complex interconnect system using our new basis functions can be reduced by a factor of 170 when compared to the use of piecewise-constant basis functions over a wide range of operating frequencies. Furthermore our volume and surface integration routines improve efficiency by an additional factor of 9.8 [1]. Our solver accuracy is validated against measurements taken on fabricated devices.

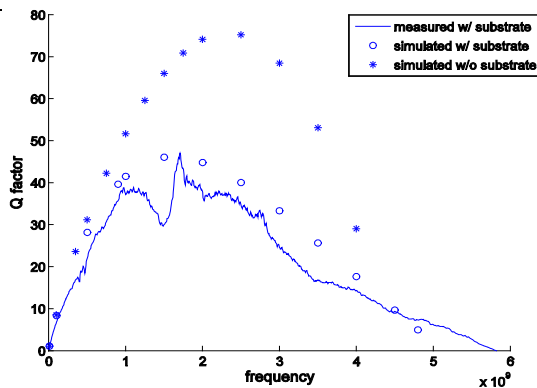

▲ Figure 1: Measured and simulated Q-factors for a square RF inductor with an area of 15mm x 15mm and surrounded by a ground ring.

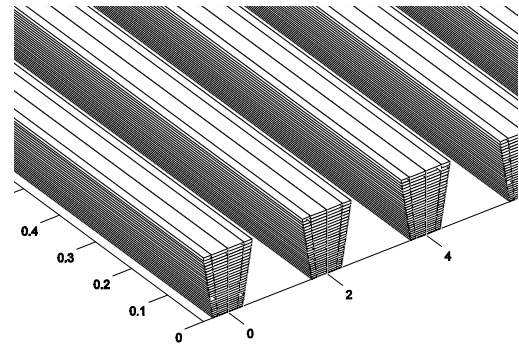

▲ Figure 2: Our basis functions avoid the expensive cross-sectional discretization shown in the figure necessary to account for trapezoidal cross-sections or skin and proximity effects.

REFERENCES

- [1] X. Hu, J.H. Lee, J. White, and L. Daniel, "Analysis of full-wave conductor-system-impedance over substrate using novel integration techniques," in *Proc. of the IEEE/ACM Design Automation Conference*, pages 147-152, June 2005.
- [2] X. Hu, T.A.E. Moselhy, J. White, and L. Daniel, "Optimization-based wideband basis functions for efficient interconnect extraction," *Design Automation and Test in Europe (DATE'07)*, April 2007.